

## Operating Instructions 19400e

Issue: 23.08.2017

Staus No.: 00240

I Modification to issue: 24.04.2001

## HTP 96, HTPI 96, OPTI 96

- I 1. **Mounting instruction:** Central mounting screws for hollow shaft encoders.

Maximum speed of all speed encoders : 10.000 rpm.

### 2. Basic circuit diagram

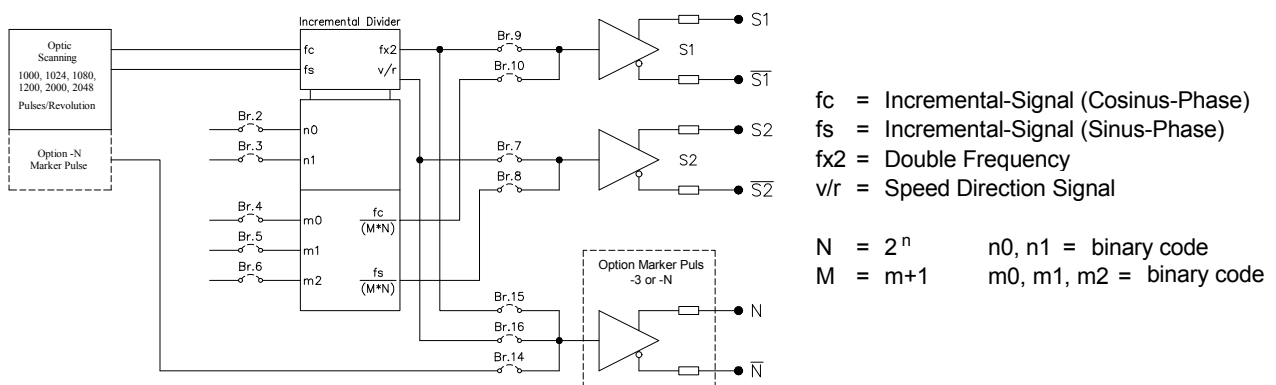

### 3. Programming instruction

#### 3.1. Output programming

For incremental encoders the divided incremental signal will be connected to pins S1 and S2 by jumpers Br.8 and Br.10. In case of 3-channel encoders (option -P3 or -PN) either the double frequency signal "fx2" (Br.15) or the speed direction signal "v/r" (Br.16) can be routed to channel "N". The double frequency signal may be routed to channel S1 (Br.9) alternatively to the divided signal. The speed direction signal may be routed to channel S2 (Br.7) alternatively to the divided signal. Signals "fx2" or "v/r" may be routed to one channel only.

#### 3.2. Programming of Pulse-Nos.

The total incremental divider is built up by two cascaded dividers. The total dividing factor is given by multiplication of divider N and M. The dividing factor  $M=7$  is not implemented. Basically all factors can be implemented, which can be realized by  $M*N$ .

The following table is showing the factors, which are realizing the basic pulse nos. 1000, 1200, 1024, 1080, 2000 and 2048 pulses per round.

3.3.

Pulse-Nos.						Divider	Br.2	Br.3	Br.4	Br.5	Br.6
1000	1024	1080	1200	2000	2048	1	--	--	--	--	--
500	512	540	600	1000	1024	2	x	--	--	--	--
		360	400			3	--	--	--	x	--
250	256	270	300	500	512	4	--	x	--	--	--
200		216	240	400		5	--	--	--	--	x
		180	200			6	--	--	x	--	x
125	128	135	150	250	256	8	x	x	--	--	--
100		108	120	200		10	x	--	--	--	x
		90	100			12	x	--	x	--	x
	64		75	125	128	16	x	x	x	--	--
50		54	60	100		20	--	x	--	--	x
		45	50			24	--	x	x	--	x
	32				64	32	x	x	x	x	--
25		27	30	50		40	x	x	--	--	x
			25			48	x	x	x	--	x
	16				32	64	x	x	x	x	x

Divider „M“	Br.4	Br.5	Br.6
1	--	--	--
2	x	--	--
3	--	x	--
4	x	x	--
5	--	--	x
6	x	--	x
8	x	x	x

Divider „N“	Br.2	Br.3
1	--	--
2	x	--
4	--	x
8	x	x

Programming will be made for encoder types in the connecting area of the encoder. Jumpers will be made by jumper plugs, connecting the relevant pins.

View after removing cover and line driver board.

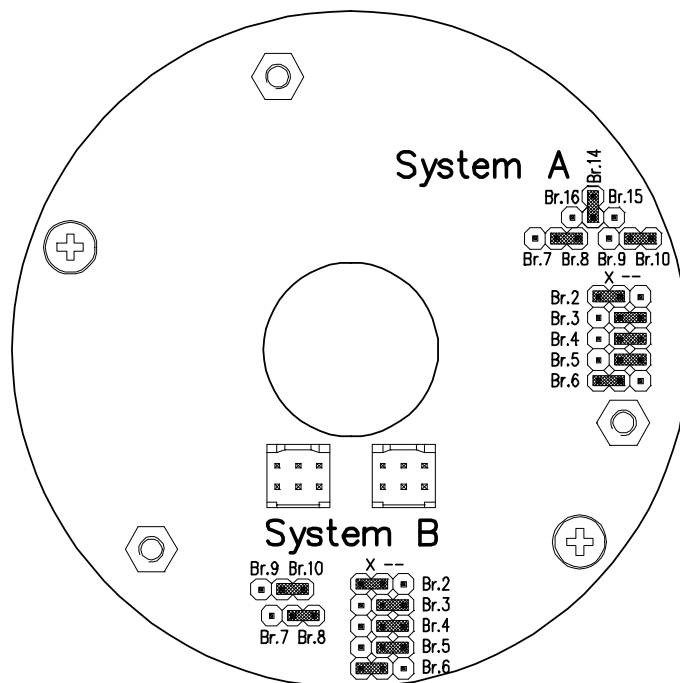

Rev-Nr.: FP P1 2005-03-29

#### 4. Connection diagram

HTP96, HTPI 96, OPTI 96, ....96 N  
 Solid shaft incremental encoder with marker pulse /  
 Hollow shaft incremental encoder with marker pulse

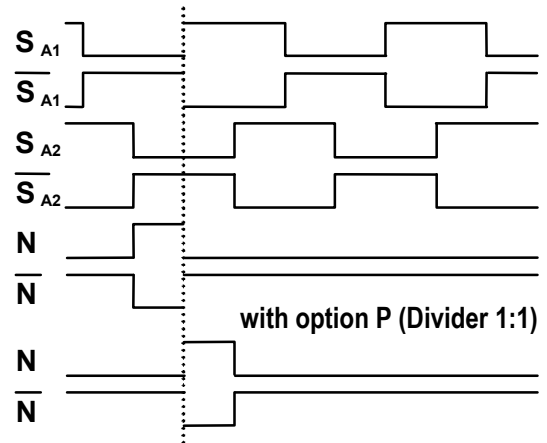
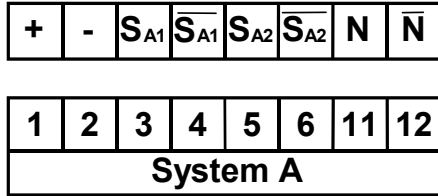

HTP96 S4, HTPI 96 S4, OPTI 96 S4, ....96 S4 N  
 Solid shaft incremental double encoder with marker pulse /  
 Hollow shaft incremental encoder with marker pulse

Connection diagram of **system A** is same as  
 HTP96, HTPI 96, OPTI 96, ....96 N

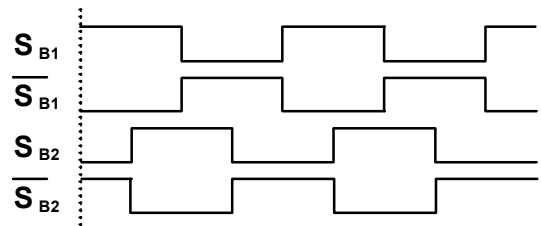
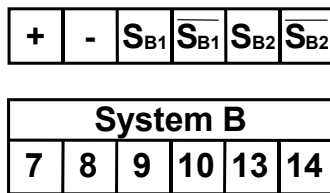

The diameter of the connection cable passing  
 the cable bushing has to be &6 ... &10 mm.

Signal diagrams at clockwise rotation of the  
 encoder shaft (view to terminal side).

#### Legend:

- +** Supply voltage ( U<sub>B</sub> )
- ( electronic- GND )
- S<sub>A1</sub> ; S<sub>B1</sub>** Signal A1 / B1
- S<sub>A1</sub> ; S<sub>B1</sub>** Signal A1 / B1 complementary
- S<sub>A2</sub> ; S<sub>B2</sub>** Signal A2 / B2
- S<sub>A2</sub> ; S<sub>B2</sub>** Signal A2 / B2 complementary
- N** Marker puls
- N** Marker puls complementary

## 5. Compatibility to previous models

### HTP 96/000, HTPI 96/000, OPTI 96/000

- Flangecompatible to HTP 87, HTPI 87, OPTI 87
- Terminal to HTP 87, HTPI 87, OPTI 87: crossover connection, because of rotated signal sequence

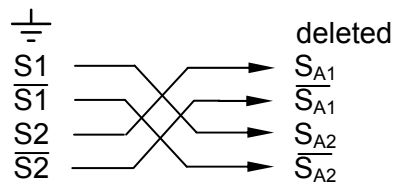

- Length of housing + 35 mm compared to HTP 87, OPTI 87
- Length of housing + 28,5 mm compared to HTPI 87

### OPTI 96/121

- Flange- and terminalcompatible to OPTI 121,  deleted
- Length of housing - 2,5 mm compared to OPTI 121
- Mounting kit for flange mounting:  
4 pcs. VA- socket screws M6 x 16 incl. spring ring and washer  
(not standard scope of Esters supply)

### OPTI 96/120

- Flange- and terminalcompatible to OPTI 120,  deleted
- Length of housing + 9,5 mm compared to OPTI 120
- Mounting kit for flange mounting:  
4 pcs. VA- socket screws M6 x 16 incl. spring ring and washer

### OPTI 96/115

- Flangecompatible to OPTI 121 S225 and OPTI 115
- Terminalcompatible to OPTI 121 S225,  deleted
- Terminal to OPTI 115: crossover connection, because of rotated signal sequence  
Flange- and terminalcompatible to OPTI 120, deleted

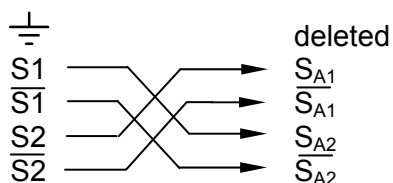

- Length of housing - 2,5 mm compared to OPTI 121 S225
- Length of housing + 35 mm compared to OPTI 115

## 6. Mounting Instruction for HTP 96/000, HTPI 96/000

### I Hollow shaft encoder with central fixing and prepared for assembly support

Assembly / Disassembly on to / off the motor shaft

#### 6.1. Switch-off the equipment and protect the drive against restart.

#### 6.2. Assembly

I At correct shaft fitting ( js6 ) mounting of the encoder on the motor shaft must be very easy. The motor shaft must not be damaged or dirty.

**Mounting with force (e.g. hammer-blows) is not permitted and will destroy the encoder!**

Assembly support:

- Screw a thread bolt (M5) into the central drill hole of the motor
- Place the encoder with removed cover on the motor shaft, so that the thread bolt is sticking out from the encoder
- Set the encoder into straight line with the motor shaft
- Screw a washer and nut (M5) on to the thread bolt and push the encoder on to the motor shaft by turning the nut
- Remove nut, washer and thread bolt

Fixing:

- I
- Central fixing at shaft's end (HTP/HTPI)  
Use socket screw M5 x 20 accord. to DIN7984 (flat head) at motor shaft length = 40 mm.  
In case of shorter motor shaft select a matching longer screw.

#### 6.3. Disassembly

Remove the screws of the hollow shaft and pull off the encoder carefully

**Attention: Do not use any force**

Bending, blows and force will destroy the encoder.

Disassembly support:

- Remove the encoder cover and release the cable connection
- Screw-in a socket screw M8 x 40 into the encoder shaft end and pull the encoder from the motor shaft by screwing-in the screw.

During the above described operations the motor probably has to be secured against rotation.