

FLOW COMPUTER GDR 1530

Gas volume in cubic meters or liters with optional standardization
for Fluidistor gas flow meter GD 300 (Ex) / GD 500 (Ex)

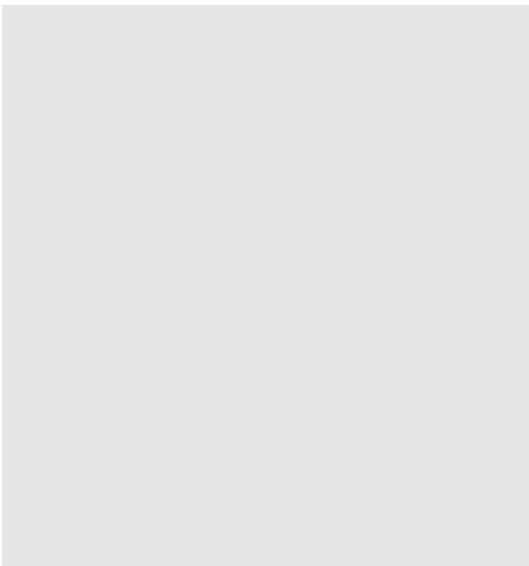

Rev. no.: GDR_1530-DS_329 E-V1.1 2023-07-21

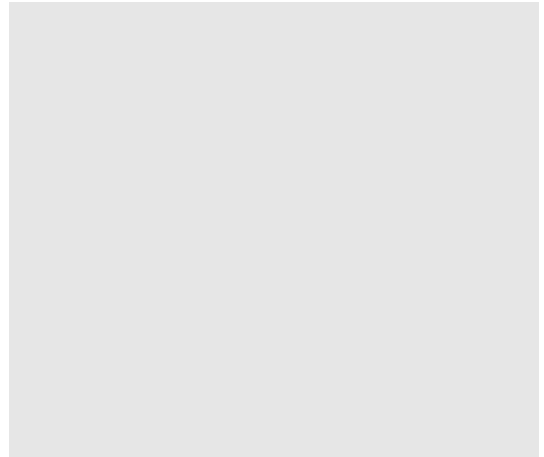
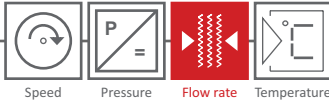

Speed Pressure Flow rate Temperature

General Description

The actual gas quantity of the gas flow meter GD 300 (Ex) / GD 500 (Ex) is calculated by the 1-channel flow computer GDR 1530.

On an hourly or minutely basis, the current gas quantity can be displayed in cubic meters or liters. The totalizer of the total quantity can be displayed either in cubic meters or in liters. The counter can have 9 digits up to 999 million cubic meters. The resolution is 0.1 liters.

2 different inputs are available for the input signal.

Gas flow meter GD 300 / GD 500:

1. Direct connection of the platinum wire sensor (NON-ATEX)
2. Connection of the HB 300 Ex (ATEX area)

The current output 0(4) - 20 mA indicates the current flow in the form of operating or standard cubic meters. Two limit values are available for limit value monitoring. Flow rate, device status or error messages can be passed on to superior PLC system via 2 semiconductor relays.

In addition to a pt100 input, the devices also have mA inputs for pressure and temperature

- 4-line display with 20 characters per line
- Multilingual menu (English, German, French, Spanish, Italian, Bulgarian, Polish, ...)
- Complete device configuration via keypad, no additional software required
- Integrated WLAN hotspot with full device access via web browser
- Security code to protect configuration
- Timestamped logging of important actions in the system logbook (device start, sensor failure, overrange, etc.)
- Easy and fast cable connection with tool-free connectors
- UV-resistant polycarbonate housing material, protection class IP 65
- Persistent counter readings for up to 5 years
- Integrated real-time clock, battery buffered for 5 years
- Standardization according to DIN 1343, DIN 6358, DIN ISO 2533, DIN 102/ISO 1-1975
- Freely scalable current output for output of actual flow rate
- Adjustable pulse weighting (0.1, 1 or 10 or 100 m³ per pulse)
- Optional data transmission via Modbus RTU and Modbus TCP



sensors as well as an integrated barometric sensor for recording the atmospheric pressure.

The standardization can be performed according to the standards DIN 1343, DIN 6358, DIN ISO 2533 or DIN 102 / ISO 1-1975.

The Modbus RTU and Modbus TCP bus systems are available as an option for data transmission.

All parameter settings/configurations can be carried out using the keys and the display or with a web browser via the integrated WLAN hotspot.

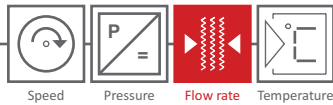

Technical details

INPUT

The devices can process one input signal of the flow rate.
The following alternatives are available for the input signal:

FLOW	Input for direct connection of the platinum wire sensor (GD 300 / GD 500) ¹⁾ or
FLOW IMPULSE INPUT	Impulse input for HB 300 / HB 300 Ex (GD 300 (Ex)/ GD 500 (Ex))
	It is possible to define a minimum threshold to differentiate between gas flow and standstill (min. flow volume suppression).

The following inputs are integrated for connecting external sensors for pressure and temperature:

TEMPERATURE	- 4 - 20 mA, 2 wire, meas. range: -100 °C - +800 °C (17 bit) or - pt100, 3/4 wire, meas. range: -100 °C - +800 °C (17 bit)
PRESSURE	4 - 20 mA, 2 wire, meas. range: -500 mbar - +1.000 bar (17 bit), (rel. or abs.)

BAROMETRIC SENSOR Integrated barometric sensor for recording the atmospheric pressure

1) only NON-ATEX applications

OUTPUT

CURRENT	0(4) - 20 mA, resolution 14 bit Flow: 0 - 100.000 m ³ /h, resolution 0,1 m ³ /h
RELAY K1, K2	2 x relay (NO) freely programmable - Pulse output (0,1, 1 or 10 or 100 m ³ per impulse, - Counter output quantity or - Limit value or - Device status

DISPLAY & RANGES OF VALUES

LCD DISPLAY	4 lines à 20 characters Size: 66 x 40mm, font size 4,8 mm Color: black on white
DATE	Acc. to ISO8601/EN28601
COUNTER PULSES	Max. 999.999.999.999.999 Pulse (1*10 ¹⁸ - 1 pulse), resolution 1 pulse (In the event of a counter overflow, the counter starts at zero.)
PULSE OUTPUT	0,001 - 1.000.000 m ³ /pulse, resolution 1/pulse Max. 10 pulses/s for Bm ³ or Nm ³
FLOW „OPERATIONAL“	Max. 100 Bm ³ /s, 360.000 Bm ³ /h
FLOW „STANDARDIZED“	Max. 1.000 Nm ³ /s, 3.600.000 Nm ³ /h
COUNTER OPERATING QUANTITY STANDARDIZED QUANTITY	Max. 99.999.999.999.999,99999999 m ³ (<1*10 ¹⁵) resolution 0,1 cm ³ Display: 99.999.999.999,9 m ³ or Nm ³ (In the event of a counter overflow, the counter starts at zero.)

Rev. no.: GDR_1530-DS_329 E-V1.1 2023-07-21

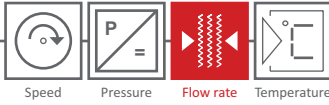

INTERFACES & ADDITIONAL FUNCTIONS

WLAN	<ul style="list-style-type: none"> - Integrated WLAN hotspot for direct connection with the device. The operation of the device can be performed via web browser. - Integration of the flow computer into the WLAN network on the plant side
MODBUS RTU ¹⁾ (OPTIONAL)	Data transmission via Modbus RTU interface
MODBUS RTU & TCP ¹⁾ (OPTIONAL)	Data transmission via Modbus RTU or TCP-interface

¹⁾ The function is activated ex works when a flow computer is ordered. The upgrade can also be activated at a later date by purchasing an activation code, provided that the hardware requirements are met.

ELECTRICAL VALUES

ACCURACY	$\pm 0,05\% \text{ EW} \pm 1 \text{ digit at } 23\text{ }^\circ\text{C}$
POWER SUPPLY	<ul style="list-style-type: none"> - 24 V, DC $\pm 3 \text{ V}$, max. 200 mA - 100 - 240 V, AC, 0,33 - 0,14 A, max. 47 - 63 Hz (optional, retrofit kit)

ENVIRONMENTAL INFLUENCES

AMBIENT TEMPERATURE	-10 to +55°C
STORAGE TEMPERATURE	-20 to +85°C
TEST VOLTAGE	3 kV
HUMIDITY CLASS	E-DIN 40040
ELECTROMAGNETIC COMPATIBILITY	acc. to EN 61000

CASING & MOUNTING OPTIONS

STANDARD CASE	<p>Polycarbonate case for wall mounting Material: polycarbonate UL 94 V0 Color: graphite gray (similar to RAL 7024), red (similar to RAL 3000) Dimensions: 151 mm (W) x 125 mm (H) x 90 mm (D) Protection class: IP 65 Net weight: approx. 650 g</p>
DIN RAIL (OPTIONAL)	Mounting parts for DIN rail mounting
MOUNTING GAS FLOW METER (OPTIONAL)	<ul style="list-style-type: none"> - Fastening element for direct mounting on gas flow meter the GD 300 / GD 500 with flange connection (only NON-ATEX applications) - Fastening element for direct mounting on gas flow meter the GD 300 / GD 500 with wafer connection (see image on page 2)



Remote access via browser

Rev.-Nr.: GDR 1530-DS 329 E-V1.1 2023-07-21

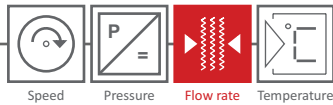

Order code

	GDR 1530
INPUT	
1: Gas flow A: Input for platinum wire sensor (GD 300/GD 500) (only NON-ATEX) <u>or</u>	•
1: Gas flow A: Impulse input for HB 300 / HB 300 Ex (GD 300 (Ex)/ GD 500 (Ex)),	•
2: Temperature ¹⁾ : 4 - 20 mA, 2 wire = -100 - 800 °C <u>or</u>	•
2: Temperature (Pt100) ¹⁾ : , 3/4 wire, -100 - 800 °C	•
3: Pressure ¹⁾ : 4 - 20 mA, 2 wire = -500 mbar - 1.000 bar	•
OUTPUT	
1: (0) 4 - 20 mA = 0 - (x) Bm ³ /h, l/h, Bm ³ /min, l/min, Nm ³ /h, NL/h, Nm ³ /min, NL/min) Flow	•
RELAY OUTPUT	
K1: Relay (NO) freely programmable	•
K2: Relay (NO) freely programmable	•
MORE FUNCTIONS	
Limit value monitoring (2 limit values)	•
Integrated barometric sensor	•
Remote control using a web browser via integrated WLAN hotspot	•
OPTIONAL FUNCTIONS	
Modbus RTU	•
Modbus RTU & Modbus TCP	•

¹⁾ Fixed values can be defined without connected sensors.

Rev. no.: GDR_1530-DS_329 E-V1.1.2023-07-21

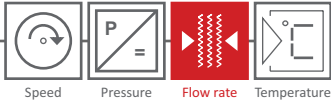

Dimensions

Standard case for GDR 1530 - wall mounting

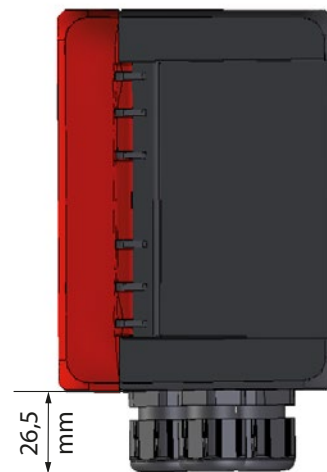
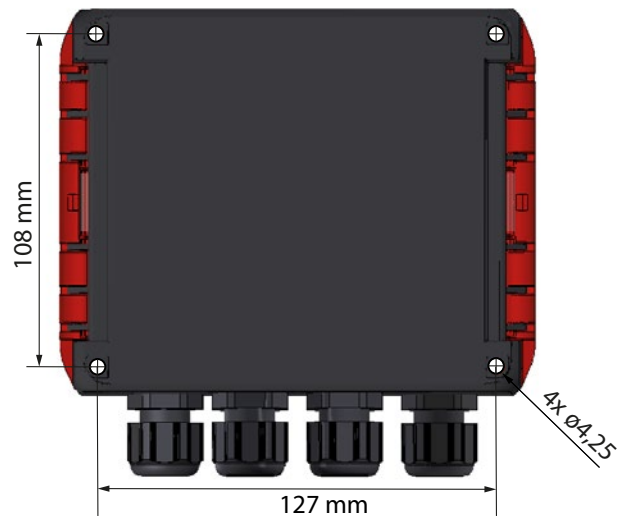
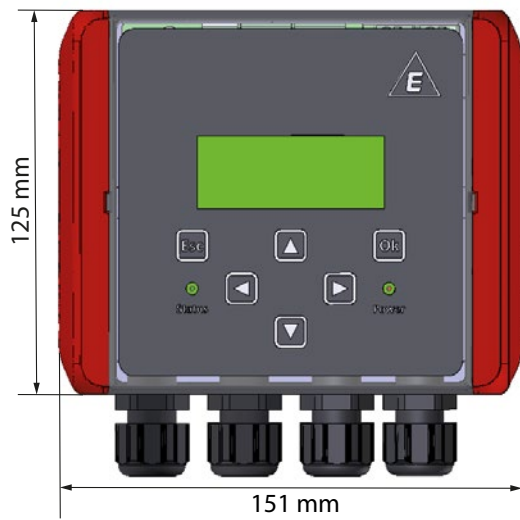

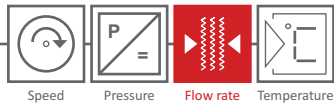

Standard case for GDR 1530 - DIN rail mounting (option HT)

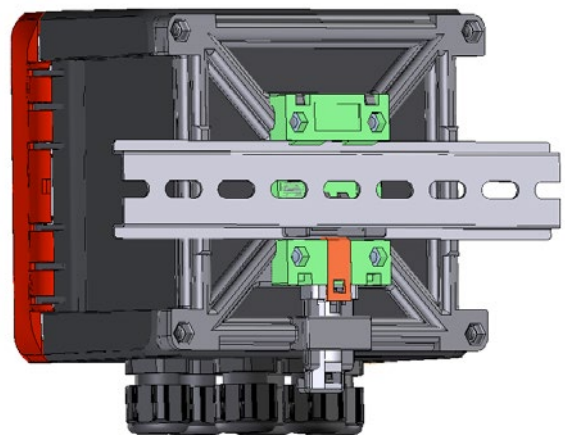
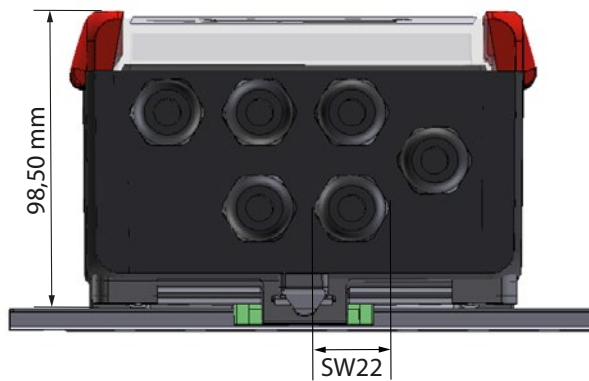
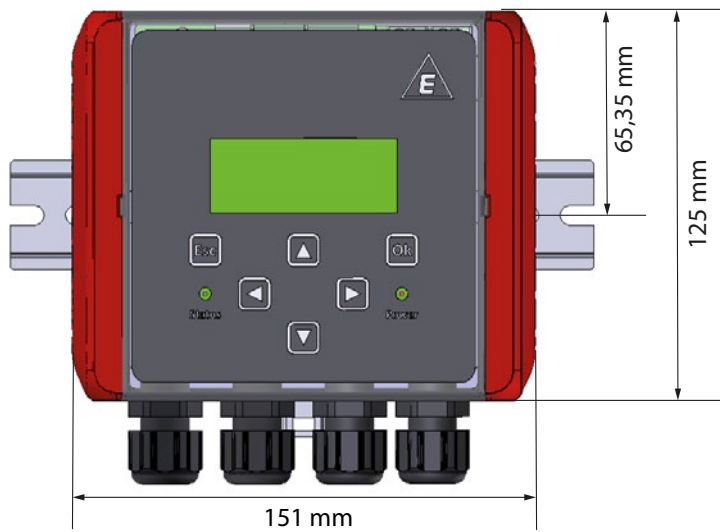

Rev. no.: GDR_1530-DS_329 E-V1.1.2023-07-21

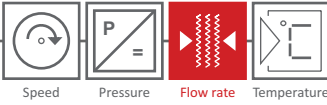

Fluidistor Gas Flowmeter GD 300 Ex

The Fluidistor Gas Flowmeter measures all technical and medical gases with a nominal width of DN 25 to DN 400 and a measurement range of 0,2 ... 20 ... 16.000 m³/h.
 Process connection: Wafer/ sandwich of flange
 Pressure: PN 10 - PN 25 - PN 40
 Accuracy: ± 1,5 %

For further information see datasheet DS 312 E.



Compact Fluidistor Gas Flowmeter GD 500 Ex

The Compact Fluidistor Gas Flowmeter (stainless steel 1.4571) measures all technical and medical gases with a measurement range of 0,21 - 16,8 m³/h.
 Process connection G 1/2", G 1".
 Pressure: PN 10 - PN 25 - PN 40
 Accuracy: ± 1,5 %

For further information see datasheet DS 312 E.

Your local contact:

Rev.-Nr.: GDR 1530-DS 329 E-V1.1 2023-07-21