

End-of-Life
successor: TR 1703

ESTERS
ELEKTRONIK 

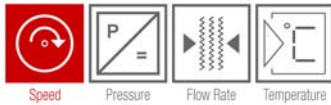

UNIVERSAL BUFFER STAGE TR 1702

for square wave, sine wave, cosine wave and frequency signal



Rev.-Nr.: DS 102 E V0.3 2014-01-03

The buffer stage serves as the galvanic separation of incremental impulses (0 - 200 KHz) and their bypass into different installation parts. It is equipped with a programmable digital divider (1 - 64) in order to process high impulse signals in to a measured data acquisition system.

All kinds of signals and divider functions can be adjusted with jumpers by the customer.

- One and multiquadrant operation
- Frequency range 0 - 200 kHz
- Input level TTL - HTL
- Output level 5-15-24 V
- Frequency divider integer (1-64) programmable (option)

End-of-Life
successor: TR 1703

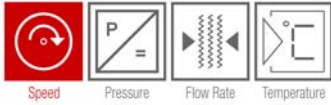

Technical data

SIGNAL INPUTS: TTL complementary RS 422
Level $I(S_{.+}) - (S_{.-}) > 0,5 V$; Impedance approx. 10 k

TTL unipolar ($S_{.-} = Gnd$)
Hi-level $> 1,9 V$; Lo-level $< 1,3 V$; Impedance approx. 5 k

HTL complementary
Level $I(S_{.+}) - (S_{.-}) > 2 V$; Impedance approx. 94 k

HTL unipolar ($S_{.-} = Gnd$)
Hi-level $> 7,5 V$; Lo-level $< 2,9 V$; Impedance approx. 47 k

TTL
UCM max = $S_{.+} \dots S_{.-} = 30 V$; $f_{max} = 200 kHz$

HTL
UCM max = $S_{.+} \dots S_{.-} = 100V$; $f_{max} = 200 kHz$

SIGNAL OUTPUTS: Hi-level = 5 V (jumper 9/2)

15 V (jumper 9/1 u. jumper 10/2)

24 V (jumper 9/1 u. jumper 10/1)

Lo-level = 0,6 V
short-circuit proof, internal resistance about 75 Ω , current approx. 50 mA

JUMPERS

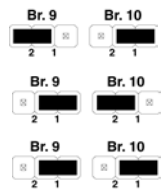
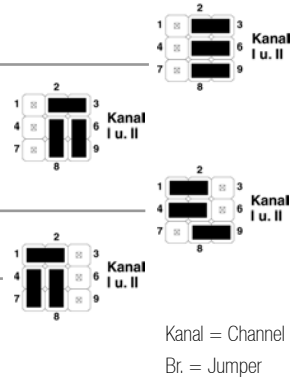

FREQUENCY RANGE:	0 - 200 kHz
SUPPLY VOLTAGE:	12 - 28 V DC; max. 8 watt
TEST VOLTAGE:	3 kV
AMBIENT TEMPERATURE:	0 - 60°C
STORAGE TEMPERATURE:	-20 - +85°C
MECHANICAL LOAD:	Shock 30 g / 18 ms (transport); 2g 0,05 ± 10 mm / 1 - 35 Hz; Operation 2 g / ± 0,15 mm, 5 - 150 Hz
ELECTROMAGNETIC LOAD:	According to EN 50082/2
MOISTURE CLASS:	E = according to DIN 40040
DESIGN:	Modular snap-in case made of Makrolon; flame-resistant class according to VL 94 : V - 0, 35 mm Standard rail according to DIN EN 50022
CONNECTION:	Self-opening plug-in connection (max. 2 x 2,5 mm ²)
DIMENSIONS:	20 mm (W) x 104 mm (H) x 110 mm (D)
PROTECTION CLASS:	IP 20

Rev.-Nr.: DS 102 E - V0.3 2014-01-03

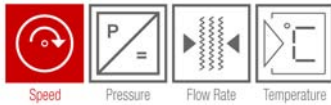

Options

P1 IMPULSE SCALER FOR INCREMENTAL SIGNALS

For the acquisition of actual values of speed, high impulse encoder frequencies are unwanted, these can be subdivided by integers in the pulse scaler. The programming is made by means of jumpers on the printed circuit board.

The following splitting ratios are possible:

1 - 2 - 3 - 4 - 5 - 6 - 8 - 10 - 12 - 16 - 20 - 24 - 32 - 40 - 48 - 64

P2 IMPULSE SCALER FOR SINGLE-COMPONENT SIGNAL

The feeding of the single-component signal is carried out on input S1 exclusively. Via internal wiring the 2nd channel (Kanal) for the frequency divider then gets simulated, which means the signal input S2 is not available any longer for external signals.

Splitting ratios and jumpers are the same as under Option P1.

P3 DIRECTION OF ROTATION - IMPULSE SUPPRESSION

Only the signal corresponding to the direction of rotation will be displayed.

S91 Programming according to customer specification

S298 Input comparator for complementary sine/ cosines wave; level ≥ 1 V

Circuit diagram

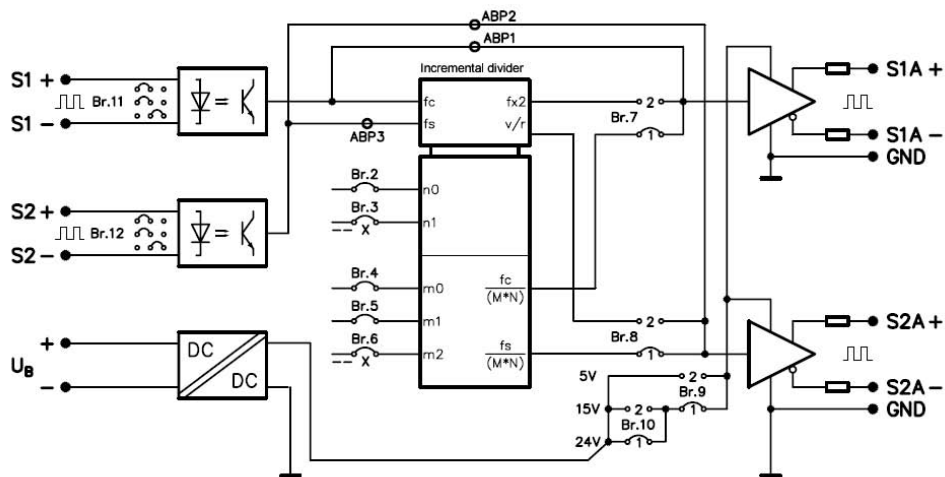

- fc = Incremental-signal (cosine phase position)
- fs = Incremental-signal (sine phase position)
- fx2 = Double signal frequency
- v/r = Direction of rotation signal
- Br. = Jumper

- N = 2^n n0, n1 = binary coded
- M = m + 1 m0, m1, m2 = binary coded

Rev-Nr.: DS 102 E V0.3 2014-01-03

End-of-Life
 successor: TR 1703

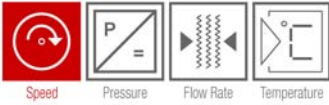

Dimension illustration

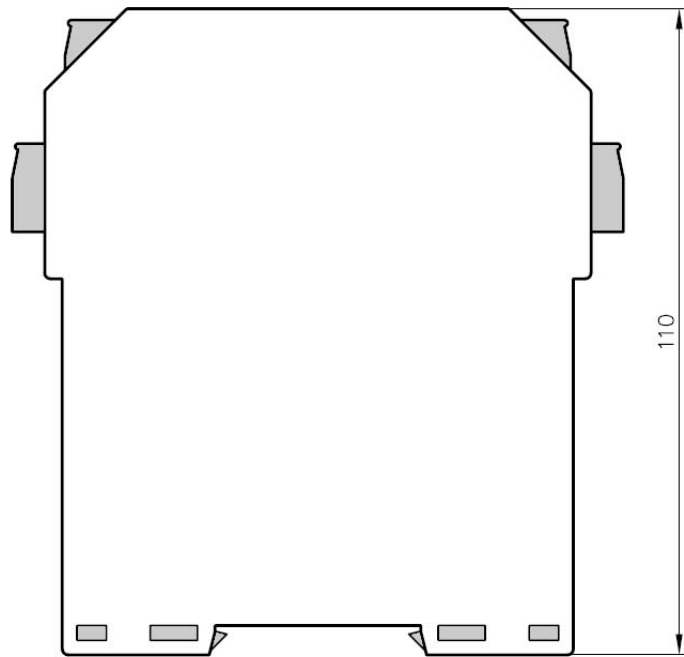
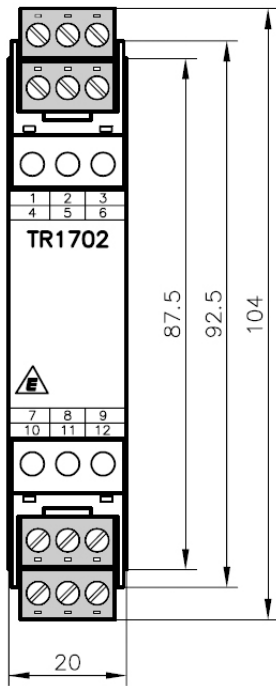

Rev.-Nr.: DS 102 E V0.3 2014-01-03

Your local contact: